

VSV/VSVI EKO

VSV 311-630 EKO

VSVI 311-630 EKO

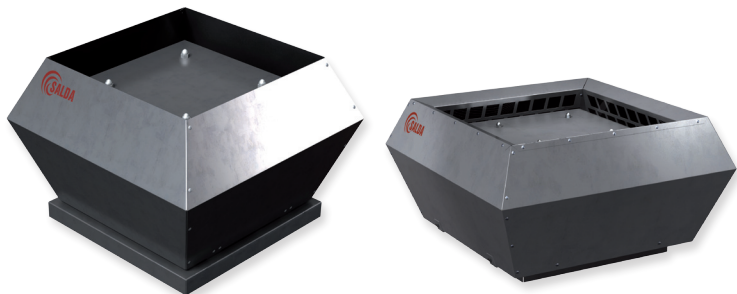

Roof fans

Stoginiai ventilatoriai

Wentylatory dachowe - wyrzut pionowy

Крышные вентиляторы

SALDA

ROOF FANS



Roof fans with vertical discharge are used to extract air from different premises. Motorised impeller is protected with a meshwork grille which protects from external objects that could cause mechanical damage to the impeller. Not suitable for polluted air, aggressive and explosive gases.

Plastic impeller with backward curved blades.

Efficient and low-noise EC fans.

VSVI EKO sound insulation: mineral wool, 50 mm thickness.

Motor: external rotor, motor protection with built-in thermal contact, maintenance free ball bearings.

Housing: made of galvanized steel. Optionally can be made of aluminium.



Stoginiai ventilatoriai, naudojami oro ištraukimui iš patalpos. Sparnuotė uždengta tinklo grotelėmis, apsaugančiomis ją nuo pašalinių daiktų, galinčių patekti iš aplinkos ir pažeisti sparnuotę mechanškai. Nenaudojami užteršto oro, agresyvių, sprogių dujų transportavimui.

Sparnuotė: atgal lenktais sparneliais, plastikinė sparnuotė. Variklis: išorinis rotorius, tiesioginė pavara, integruota termokontaktinė variklio apsauga, ilgai tarnaujantys nereikalaujantys priežiūros guoliai.

Efektyvūs ir tylūs EC ventilatoriai.

Korpusas: iš cinkuotos skardos. Galima pasirinkti modelį VSV EKO AL, kuris pagamintas iš aliuminio.

VSVI ir VSVI AL EKO garso izoliacija: 50 mm mineraline vata.



Wentylatory dachowe z pionowym wyrzutem służą do wyciągu powietrza z różnych pomieszczeń. Wirniki są osłonięte blachą perforowaną która chroni przed zewnętrznymi czynnikami, które mogą powodować mechaniczne uszkodzenie wirnika. Nie nadają się do zastosowań w środowiskach agresywnych chemicznie oraz zagrożonych wybuchem. Nie zaleca się stosować w instalacjach zanieczyszczonych cząstkami stałymi, pyłami i odpadami technologicznymi. Nie stosować w instalacjach oddymiania, przeciwpożarowych, spalinowych.

Wirnik: plastikowy z łopatkami wygiętymi do tyłu.

Silnik: wydajne i ciche silniki EC, silnik z wirnikiem zewnętrznym, zabezpieczenie z wbudowanym bezpiecznikiem termicznym, bezobsługowe łożyska kulkowe.

Korpus: wykonany z ocynkowanej stali - opcjonalnie wykonane z aluminium. VSVI EKO izolacja akustyczna: wełna mineralna 50 mm grubości.



Крышные вентиляторы для вытяжки воздуха из помещений. Крыльчатка закрыта сетчатой решёткой, защищающей её от попадающих извне посторонних предметов, способных механически повредить крыльчатку. Не используются при транспортировке загрязнённого воздуха, агрессивных, взрывоопасных газов.

Крыльчатка: загнутые назад лопатки, сделано из пластика.

Экономные и бесшумные EC вентиляторы.

VSVI EKO звукоизоляция: каменная вата, толщиной 50 мм.

Двигатель: наружный ротор, прямая передача, встроенные термоконтакты двигателя, не требующие ухода подшипники с длительным сроком службы.

Корпус: оцинкованной жести. Может быть изготовлено и из алюминия.

Accessories

0-10V speed controller



Roof curb



Roof curb



Flange-adapter



Flexible connection



Back draft shutter



Main switch



VSV/VSVI EKO

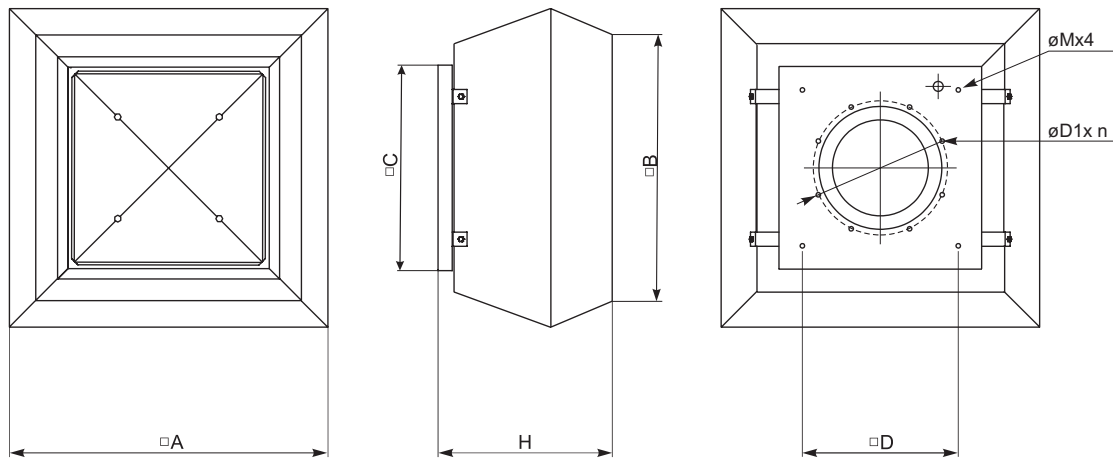

SALDA

ROOF FANS

Type	Dimensions [mm]							
	□A [mm]	□B [mm]	□C [mm]	□H [mm]	∅M [mm]	□D [mm]	∅D1	n
VSV 311 EKO	555	470	435	323	M6	330	-	-
VSV 355 EKO	720	618	595	420	M10	450	-	-
VSV 400 EKO	720	618	595	420	M10	450	-	-
VSV 450 EKO	900	700	665	485	M10	535	-	-
VSV 500 EKO	900	700	665	485	M10	535	-	-
VSV 560 EKO	1150	972	939	609	M10	750	-	-
VSV 630 EKO	1150	972	939	609	M10	750	-	-
VSVI 311 EKO	675	567	435	370	M6	330	285	6
VSVI 355 EKO	844	716	595	420	M10	450	438	6
VSVI 400 EKO	844	716	595	420	M10	450	438	6
VSVI 450 EKO	966	817	665	488	M10	535	438	6
VSVI 500 EKO	966	817	665	488	M10	535	438	6
VSVI 560 EKO	1265	1033	939	611	M10	750	605	8
VSVI 630 EKO	1265	1033	939	611	M10	750	605	8

Type	Accessories					
	MTP010	KS-K	KSP-K	FSV	LSV	ATS
VSV/VSVI 311 EKO	+	311	311	311	311	311
VSV/VSVI 355 EKO	+	355/500	355/400	355/400	355/400	355/400
VSV/VSVI 400 EKO	+	355/500	355/400	355/400	355/400	355/400
VSV/VSVI 450 EKO	+	450/500	450/500	450/500	450/500	450/500
VSV/VSVI 500 EKO	+	450/500	450/500	450/500	450/500	450/500
VSV/VSVI 560 EKO	+	560/630	560/630	560/630	560/630	560/630
VSV/VSVI 630 EKO	+	560/630	560/630	560/630	560/630	560/630

VSV/VSVI EKO

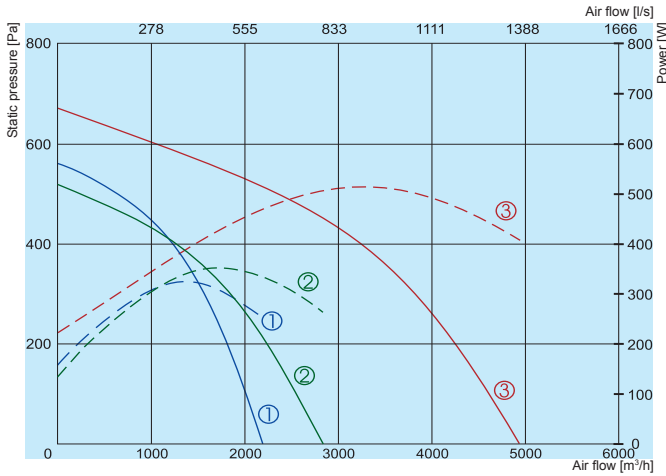

- ① — VSV/VSVI 311 L1 EKO
 - ② — VSV/VSVI 355 L1 EKO
 - ③ — VSV/VSVI 400 L1 EKO
- Performance
- - - Power consumption

		311 L1 EKO	355 L1 EKO	400 L1 EKO
Voltage/Frequency	[V/Hz]	230/50	230/50	230/50
Power consumption	[kW]	0,323	0,350	0,772
Current	[A]	1,51	1,61	3,5
Speed	[min ⁻¹]	2270	2010	1700
Max. airflow	[m ³ /h]	2185	2835	4940
Min./Max. air temperature	[°C]	-25/60	-15/60	-25/60
Weight	[kg]	20/24	30/38	33/38
Wiring diagram		No.1	No.1	No.2
Protection class:	motor	IP-54	IP-54	IP-54
	terminal box	IP-55	IP-55	IP-54
Comply with ERP 2013; 2015		+	+	+

VSV 311 L1 EKO

	Lwa total, dB(A)	Lwa, dB(A)						
		125 Hz	250 Hz	500 Hz	1 kHz	2 kHz	4 kHz	8 kHz
Inlet	75	51	63	72	68	67	64	61
Outlet	76	56	62	71	72	66	65	59
Surrounding	78	56	67	73	72	71	68	63

Measured at 1901 m³/h, 150 Pa

VSV 355 L1 EKO

	Lwa total, dB(A)	Lwa, dB(A)						
		125 Hz	250 Hz	500 Hz	1 kHz	2 kHz	4 kHz	8 kHz
Inlet	75	51	63	70	67	70	65	60
Outlet	76	54	67	68	70	70	66	58
Surrounding	78	58	68	71	73	72	68	63

Measured at 2816 m³/h, 172 Pa

VSV 400 L1 EKO

	Lwa total, dB(A)	Lwa, dB(A)						
		125 Hz	250 Hz	500 Hz	1 kHz	2 kHz	4 kHz	8 kHz
Inlet	79	62	74	75	71	66	66	60
Outlet	78	66	71	72	71	70	66	61
Surrounding	82	68	77	77	73	71	69	64

Measured at 4370 m³/h, 183 Pa

VSVI 311 L1 EKO

	Lwa total, dB(A)	Lwa, dB(A)						
		125 Hz	250 Hz	500 Hz	1 kHz	2 kHz	4 kHz	8 kHz
Inlet	74	52	61	70	68	66	62	61
Outlet	74	56	63	69	70	67	63	59
Surrounding	77	57	65	73	72	70	66	63

Measured at 1901 m³/h, 150 Pa

VSVI 355 L1 EKO

	Lwa total, dB(A)	Lwa, dB(A)						
		125 Hz	250 Hz	500 Hz	1 kHz	2 kHz	4 kHz	8 kHz
Inlet	74	49	62	69	67	68	65	59
Outlet	74	55	65	66	70	68	64	58
Surrounding	77	56	67	71	71	71	68	62

Measured at 2816 m³/h, 172 Pa

VSVI 400 L1 EKO

	Lwa total, dB(A)	Lwa, dB(A)						
		125 Hz	250 Hz	500 Hz	1 kHz	2 kHz	4 kHz	8 kHz
Inlet	78	62	75	73	68	66	65	59
Outlet	77	64	70	71	71	68	66	60
Surrounding	81	66	76	75	73	70	69	63

Measured at 4370 m³/h, 183 Pa

The fan characteristic curves were determined in accordance with EN ISO 5801. The sound levels were determined in accordance with DIN 45635 resp. ISO 3744 at a distance of 1 m from the fan.

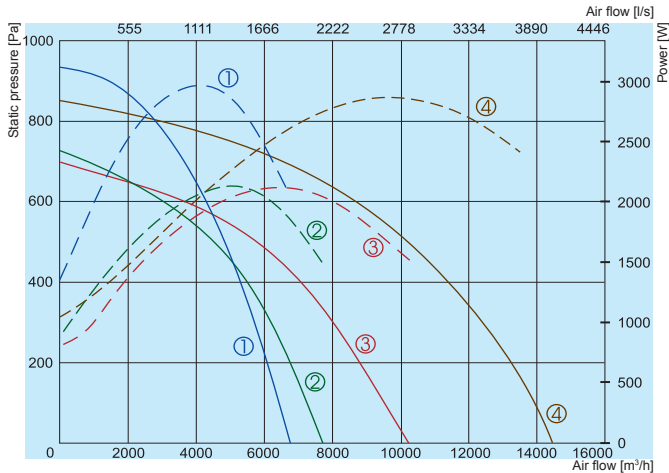

- ① VSV/VSVI 450 L3 EKO
 - ② VSV/VSVI 500 L3 EKO
 - ③ VSV/VSVI 560 L3 EKO
 - ④ VSV/VSVI 630 L3 EKO
- Performance
- - - Power consumption

		450 L3 EKO	500 L3 EKO	560 L3 EKO	630 L3 EKO
Voltage/Frequency	[V/Hz]	400/50	400/50	400/50	400/50
Power consumption	[kW]	1,418	1,28	1,595	2,87
Current	[A]	2,22	2,02	2,51	4,42
Speed	[min ⁻¹]	1800	1400	1230	1230
Max. airflow	[m ³ /h]	6760	7670	10220	14500
Min./Max. air temperature	[°C]	-25/60	-25/60	-25/40	-25/60
Weight	[kg]	50/60	50/60	82/100	103/121
Wiring diagram		No.2	No.2	No.2	No.2
Protection class:	motor	IP-54	IP-54	IP-54	IP-54
	terminal box	IP-54	IP-54	IP-54	IP-54
Comply with ERP 2013; 2015		+	+	+	+

VSV 450 L3 EKO

LWA total, dB(A)	Lwa, dB(A)							
	125 Hz	250 Hz	500 Hz	1 kHz	2 kHz	4 kHz	8 kHz	
Inlet	83	66	77	80	74	73	71	69
Outlet	85	71	77	80	78	76	73	69
Surrounding	87	71	78	83	80	76	75	72

Measured at 6345 m³/h, 121 Pa

VSV 500 L3 EKO

LWA total, dB(A)	Lwa, dB(A)							
	125 Hz	250 Hz	500 Hz	1 kHz	2 kHz	4 kHz	8 kHz	
Inlet	79	66	74	75	68	67	67	66
Outlet	80	69	74	75	73	70	68	64
Surrounding	83	70	75	79	76	72	71	68

Measured at 7139 m³/h, 120 Pa

VSV 560 L3 EKO

LWA total, dB(A)	Lwa, dB(A)							
	125 Hz	250 Hz	500 Hz	1 kHz	2 kHz	4 kHz	8 kHz	
Inlet	78	69	73	72	70	68	66	62
Outlet	78	69	71	73	70	69	66	59
Surrounding	81	72	73	75	73	71	70	65

Measured at 9113 m³/h, 160 Pa

VSV 630 L3 EKO

LWA total, dB(A)	Lwa, dB(A)							
	125 Hz	250 Hz	500 Hz	1 kHz	2 kHz	4 kHz	8 kHz	
Inlet	82	65	75	79	75	72	71	65
Outlet	83	70	74	80	76	72	72	68
Surrounding	85	72	77	82	76	75	75	69

Measured at 13018 m³/h, 230 Pa

VSVI 450 L3 EKO

LWA total, dB(A)	Lwa, dB(A)							
	125 Hz	250 Hz	500 Hz	1 kHz	2 kHz	4 kHz	8 kHz	
Inlet	82	67	75	79	72	72	71	68
Outlet	84	69	76	79	78	74	73	68
Surrounding	86	71	79	82	79	76	75	71

Measured at 6345 m³/h, 121 Pa

VSVI 500 L3 EKO

LWA total, dB(A)	Lwa, dB(A)							
	125 Hz	250 Hz	500 Hz	1 kHz	2 kHz	4 kHz	8 kHz	
Inlet	78	67	72	74	67	67	67	65
Outlet	79	67	73	74	73	68	68	62
Surrounding	82	70	76	77	74	71	71	67

Measured at 7139 m³/h, 120 Pa

VSVI 560 L3 EKO

LWA total, dB(A)	Lwa, dB(A)							
	125 Hz	250 Hz	500 Hz	1 kHz	2 kHz	4 kHz	8 kHz	
Inlet	77	69	71	70	68	68	66	61
Outlet	77	67	70	72	70	68	66	58
Surrounding	80	71	74	74	72	71	69	63

Measured at 9113 m³/h, 160 Pa

VSVI 630 L3 EKO

LWA total, dB(A)	Lwa, dB(A)							
	125 Hz	250 Hz	500 Hz	1 kHz	2 kHz	4 kHz	8 kHz	
Inlet	81	65	73	78	73	70	71	63
Outlet	82	69	74	78	74	71	72	67
Surrounding	84	70	76	81	76	74	75	68

Measured at 13018 m³/h, 230 Pa

The fan characteristic curves were determined in accordance with EN ISO 5801. The sound levels were determined in accordance with DIN 45635 resp. ISO 3744 at a distance of 1 m from the fan.

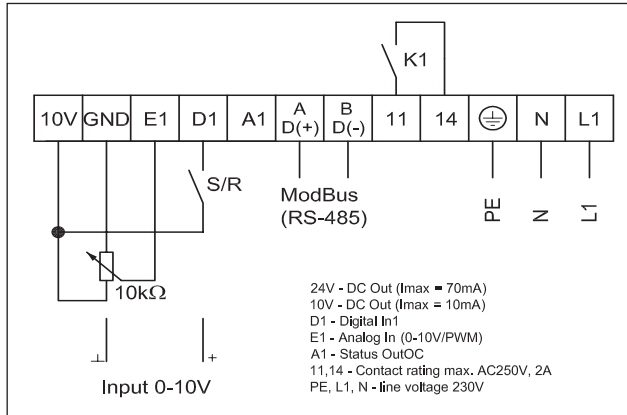

Wiring diagram No. 1

- PE - yellow - green
- BU - blue
- BN- brown
- RD - red
- GN - green
- YE - yellow
- WH - white
- GY - gray

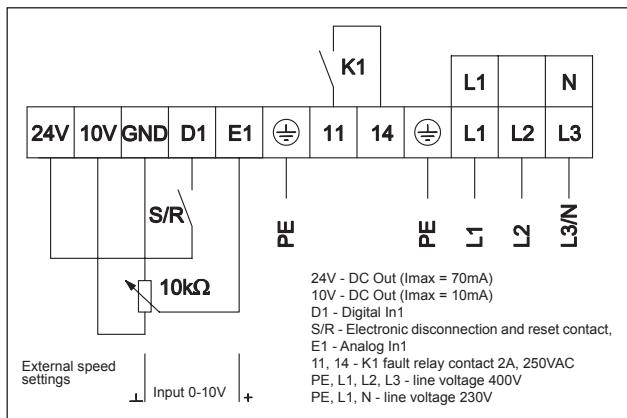

Wiring diagram No. 2